

## Electromagnetic Multi-Disc Brake

Brake with outside-driver for the slow-down of the shaft against a idle gear part.

For wet and dry operation, coil voltage 24 V DC

- ◆ Clutch wit adjustable air gap.
- ◆ High energy absorption by wear resistant steel- / sinter discs.
- ◆ Effective heat dissipation by peripheral friction faces.
- ◆ For horizontal mounting.

The brake is for both, the installation outside of gears and for wet operated gears. The magnetic flux is not going through the multi-disc packet and enables the use of not magnetized multi-discs. The current supply occurs through 2 connecting wires. One of the wires can be used for the return of current via ground (-).

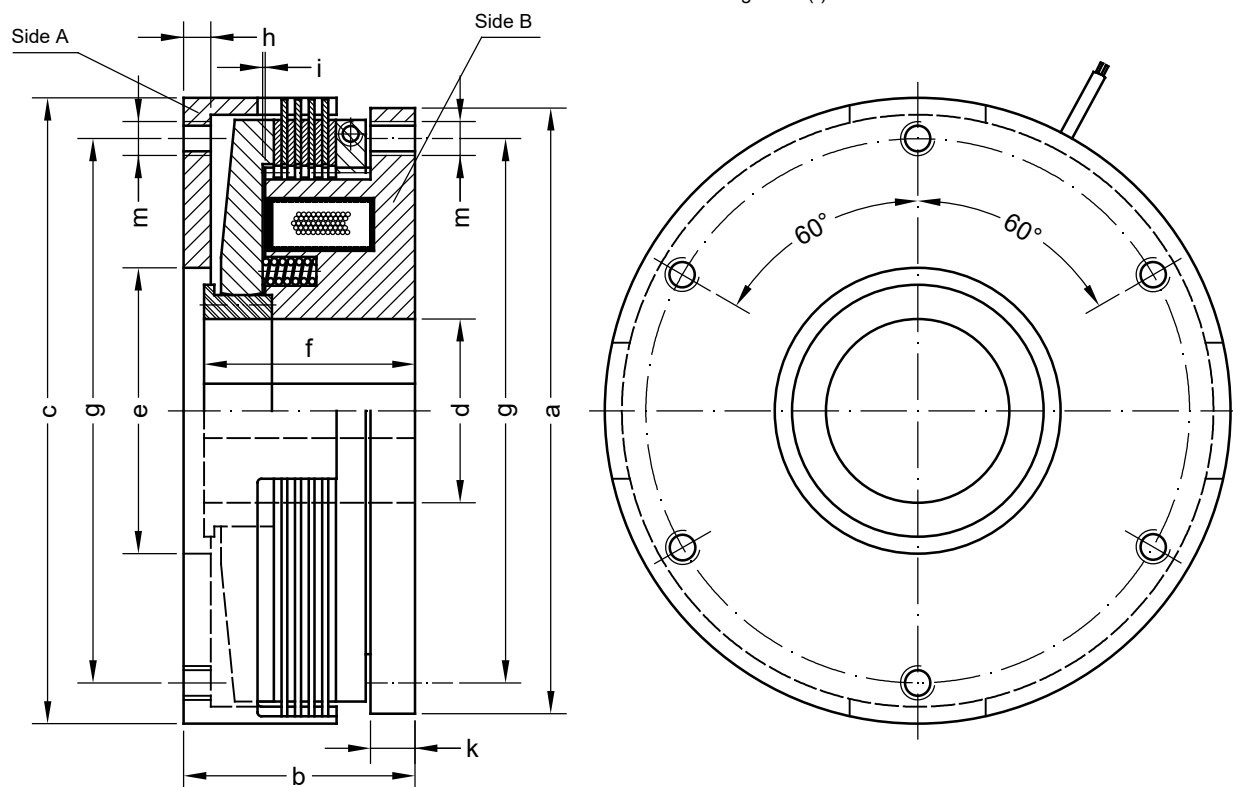

Data and Dimensions		LMB 1,6	LMB 2,5	LMB 4	LMB 6,3	LMB 10	LMB 16	LMB 25	LMB 40	LMB 63	LMB 100	LMB 160	LMB 250	
wet operation	Static torque	Nm	25	40	63	100	160	250	400	630	1000	1600	2500	4000
	Dynamic torque	Nm	16	25	40	63	100	160	250	400	630	1000	1600	2500
	Idling torque	Nm	0,1	0,2	0,3	0,35	0,45	0,6	0,8	1,1	2,2	3,5	5	10
	Friction work per engagement	kJ	10	15	20	25	35	40	70	90	150	250	300	500
	Thermal capacity	W	90	120	130	170	250	330	450	550	770	1000	1250	1600
dry operation	Static torque	Nm	40	80	120	180	300	500	800	1200	1800	3000	5000	8000
	Dynamic torque	Nm	25	50	80	120	200	320	500	800	1200	2000	3200	5000
	Idling torque	Nm	0,05	0,08	0,12	0,16	0,25	0,4	0,5	0,6	1	1,4	1,6	2,4
	Friction work per engagement	kJ	2,5	4	5	6	8	12	18	25	35	60	80	110
	Thermal capacity	W	30	45	50	70	90	110	150	200	300	400	550	700
Speed maximum	min <sup>-1</sup>	3800	3500	3500	3200	3000	2600	2300	2100	1900	1700	1500	1300	
Coil power consumption at 20°	W	25	28	32	34	45	54	63	75	85	110	140	155	
Mass moment of inertia side A	10 <sup>-3</sup> kgm <sup>2</sup>	0,7	1,3	1,4	2,6	4,5	8	15	22	42	80	160	380	
Mass moment of inertia side B	10 <sup>-3</sup> kgm <sup>2</sup>	1,5	2,6	3	6,5	10,5	17	32	60	115	250	500	1000	
mass (weight)	kg	2	2,6	2,9	4	5,5	7,5	11	14,5	21	33	45	75	
Ø a	mm	100	110	120	132	145	160	180	200	230	255	295	340	
b	mm	45	48	52	55	58	62	68	76	86	100	115	132	
Ø c	mm	97	112	115	133	147	158	180	198	235	265	290	355	
Ø d max H7	mm	25	30	32	35	42	48	55	60	70	80	90	120	
Ø e min H7	mm	50	50	50	60	70	80	90	100	100	110	140	180	
f	mm	42	45	48	50	53	57	63	70	80	92	107	122	
Ø g	mm	85	90	100	105	120	135	155	170	200	235	260	305	
h	mm	5	5	6	7	7	7	8	9	10	12	14	15	
i air gap (clutch engaged)	mm	0,3	0,3	0,3	0,3	0,35	0,4	0,45	0,5	0,6	0,7	0,8	0,9	
k	mm	6	6	6	7	7	7	8	9	10	12	14	15	
m	mm	M6	M6	M6	M8	M8	M8	M10	M10	M12	M12	M16	M16	