

Electromagnetic Stationary Field Tooth Clutch

Clutch for positive torque transmission between shaft and bearing mounted gear part.

For oil and dry operation, coil voltage 24 V DC

- ◆ With point shaped backlash-free tooth profile.
- ◆ For engagement under limited relative speed.
- ◆ Version 1 - tooth angle 55° for disengagement under torque load.
- ◆ Version 2 - tooth angle 35° for higher torque transmission, if disengagement without torque load takes place.
- ◆ Suited for horizontal and vertical mounting.

Small tooth clutch for positive torque transmission by two face gears, for operating mechanism and precise mechanical equipments.

The torque connection is effected by the hardened face teeth with point-shaped profile and the yaws of the clutch hub guidance. When the clutch is electrically switched off, the toothed armature body carrying the magnet body is retained in disengaged position by release springs.

Engagement at stand still or engagement speed according to table.

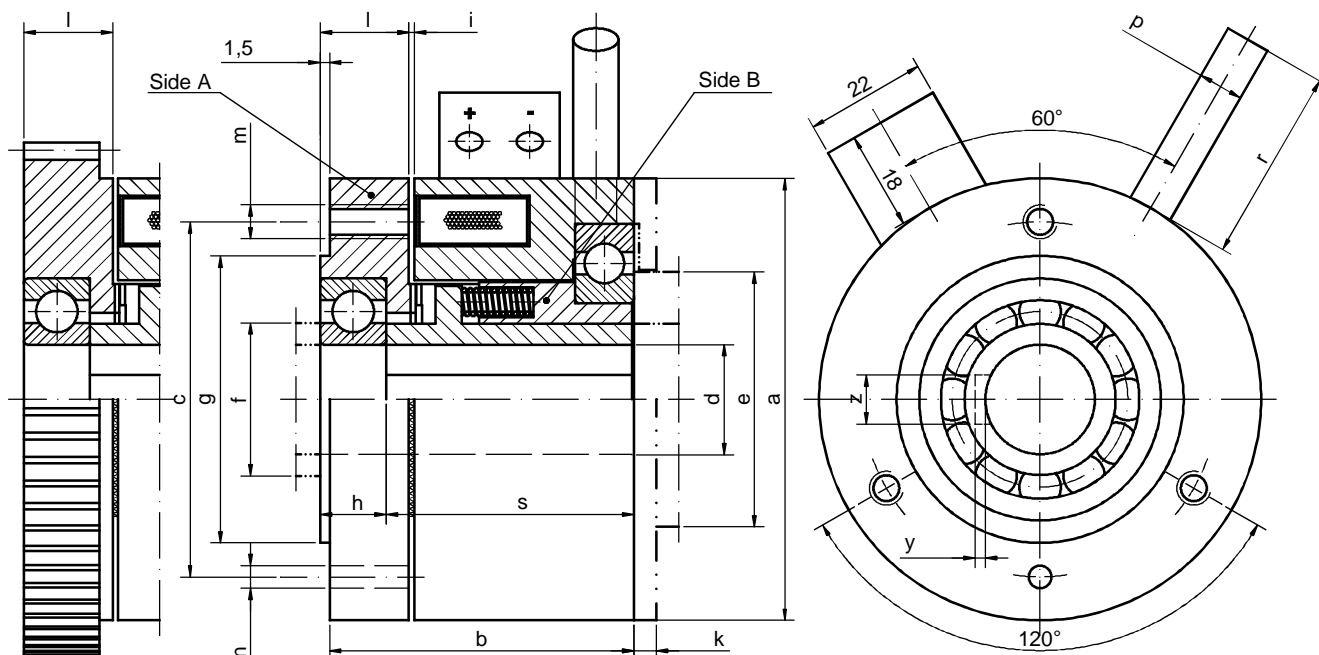

Data and Dimensions				FZND 0,5 ^{*)}	FZND 1 ^{*)}	FZND 2	FZND 4
Static torque continuous (static) torque load	Version	1	Nm	3,2	6,3	12,5	25
		2	Nm	6,3	12,5	25	50
Static torque fluctuating (dynamic) torque load	Version	1	Nm	2,5	5	10	20
		2	Nm	5	10	20	40
Engagement speed up to - - - without torque load			min ⁻¹	200	125	80	50
Speed maximum			min ⁻¹	3500	3000	2500	2000
Coil power consumption at 20 °C			W	15	20	25	30
Mass moment of inertia side A			10 ⁻⁶ kgm ²	2,1	4,9	10,4	30,5
Mass moment of inertia side B			10 ⁻⁶ kgm ²	0,6	1,2	1,9	5,1
Mass (weight)			kg	0,33	0,53	0,84	1,5
ø a			mm	42	50	59	72
b			mm	33	37	42	50
ø c			mm	36	41	48	60
ø d H7			mm	12	12	15	20
ø e			mm	25	25	32	38
ø f			mm	16	16	21	26
ø g g6			mm	31	32	38	48
h			mm	8	8	9	12
i clutch engaged / disengaged			mm	0,1 / 0,8	0,1 / 0,8	0,1 / 0,8	0,1 / 0,8
k			mm	3	3	3	3
l			mm	10	11	12	16
m			mm	M4	M4	M5	M5
ø n prebored / for dowel			mm	3 / 4	3 / 4	3 / 4	3 / 4
ø p x r			mm	5 x 40	5 x 40	6 x 40	6 x 60
s			mm	25	29	33	38
y			mm	1,1	1,1	1,3	1,6
z			mm	4	4	5	6

^{*)} Only on request - minimum quantity 5 pieces!