

Electromagnetic Stationary Field Spring-Pressure Multi-Disc Clutch

Safety clutch with outer driver for main drives.

For dry operation, coil voltage 24 or 90 V DC

- ◆ Safety clutch for drives in hoisting equipment.
- ◆ With wear resistant steel- / sinter discs.
- ◆ Compensation of disc wear by adjustable air gap.
- ◆ Design variations:
- ◆ Version 1: For constant operation engaged or released.
- ◆ Version 2: High torque execution - not constantly released.
- ◆ For horizontal mounting.

At rest the clutch is frictional engaged. The torque connection is also maintained in case of power outage, thus granting a definite protective function.

Typical fields of application are hoists, winches, lifting platform drives and various loading equipments.

By means of the energy stored in the pressure springs, short engagement times and rapid torque rise are obtained.

FMOV - version 2 permissible release time ~ 50 percent of operation time.

Available in special design suitable for combustion-engine applications.

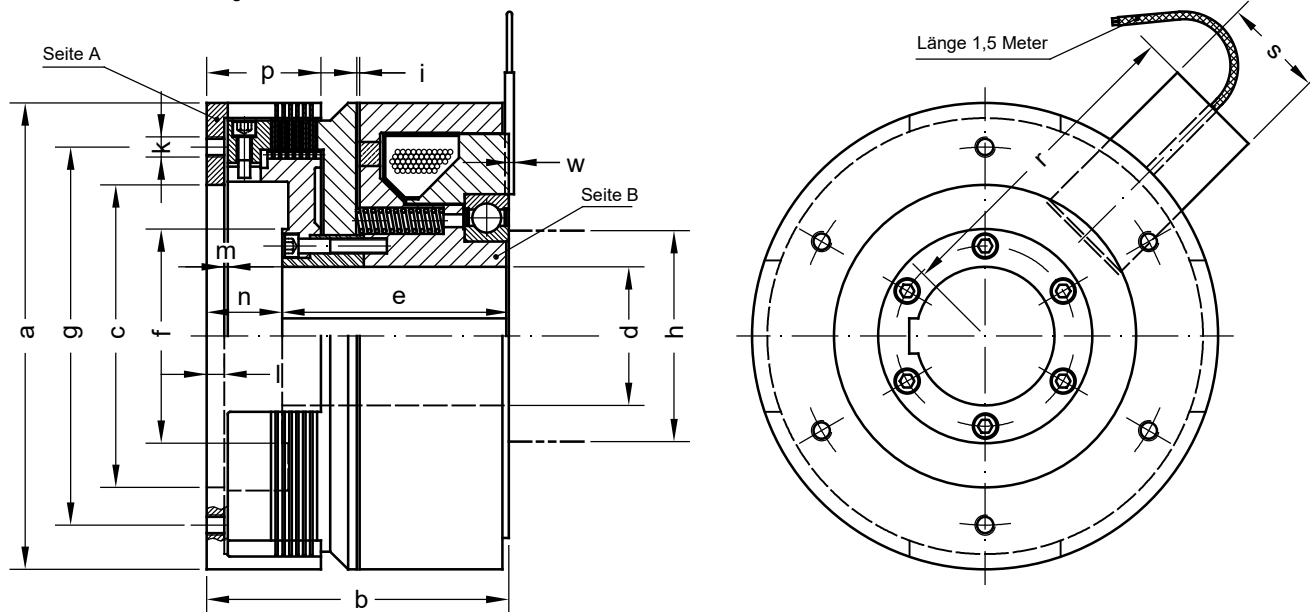

Data and Dimensions			FMOV 10	FMOV 20	FMOV 40	FMOV 80	FMOV 160	FMOV 315	FMOV 630	FMOV 1000
Static torque	Version 1	Nm	100	200	400	800	1600	3200	6300	10000
		Nm	63	125	250	500	1000	2000	4000	6300
Static torque	Version 2	Nm	160	320	630	1250	2500	5000	10000	16000
		Nm	100	200	400	800	1600	3200	6300	10000
Friction work per engagement		kJ	15	20	40	80	120	180	360	750
Thermal capacity		W	120	160	250	400	600	800	1200	2000
Speed maximum		min ⁻¹	3200	3000	2500	2100	1700	1300	1000	800
Engagement time		~ ms	25	35	50	70	100	140	250	500
Coil power at 20°C	Version 1	for unlimited release time	W	65	86	95	125	135	165	185
	Version 2	for limited release time	W	90	130	160	205	230	300	250
Mass moment of inertia side A		kgm ²	0,0045	0,0107	0,0279	0,0675	0,1423	0,3696	1,1366	3,4567
Mass moment of inertia side B		kgm ²	0,0165	0,0404	0,1025	0,2267	0,5787	1,0797	5,3338	16,2512
Mass (weight)		kg	8	15,5	27	45	76	142	280	545
Ø a		mm	145	175	210	248	297	370	460	575
b		mm	102	118	145	170	195	240	300	370
Ø c H7		mm	85	100	125	150	180	240	290	360
Ø d H7 max.		mm	40	50	60	70	85	110	130	160
e		mm	70	84	100	120	145	180	225	276
Ø f		mm	70	82	100	120	140	170	210	260
Ø g		mm	120	140	170	200	240	300	375	470
Ø h		mm	55	75	90	110	135	170	200	245
i clutch gap		mm	1,0 - 1,3	1,2 - 1,5	1,4 - 1,8	1,7 - 2,2	1,8 - 2,3	2,2 - 2,8	2,5 - 3,1	2,8 - 3,4
k		mm	6 x M6	6 x M6	6 x M8	6 x M10	6 x M12	6 x M16	6 x M16	6 x M20
l		mm	7	8	10	12	12	14	18	22
m		mm	2	2	2	2	2	3	4	5
n		mm	32	34	45	50	50	60	75	94
p		mm	43	46	58	69	78	91	116	145
r / s		mm	115 / 25	125 / 25	160 / 40	175 / 40	200 / 40	270 / 70	310 / 70	380 / 90
w		mm	3	3	3	3	4	4	4	6,5
keyway DIN 6885 - 1		-	1	1	1	2	2	2	2	2