

## Electromagnetic Slip Ring Multi-Disc Clutch

Clutch with magnet body end face, fastened to bearing mounted gear part.

For oil operation, coil voltage 24 V DC

- ◆ With one slip ring (+) and ground connection (-).
- ◆ With wear resistant, specially heat treated steel discs.
- ◆ High torque in comparison with the size.
- ◆ Inner driver (extra accessory) with hardened teeth.
- ◆ For horizontal mounting.

The clutch is suited for speed engagement of main and auxiliary drives and is intended for the installation into oil lubricated gears.

A double magnetic flux circulates through the steel discs.

The clutch thereby automatically compensates for the disc wear and does not need to be adjusted.

Extras: Inner driver, plunger brush gear with brushes.

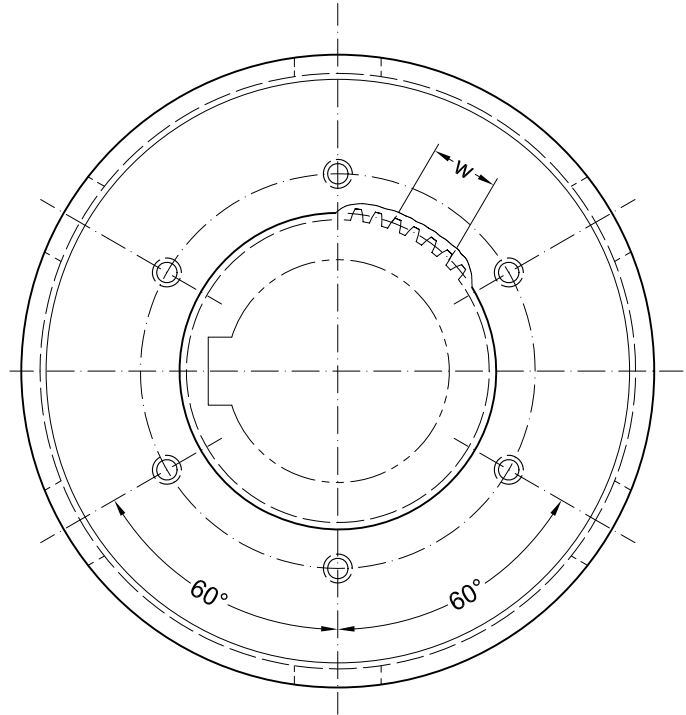
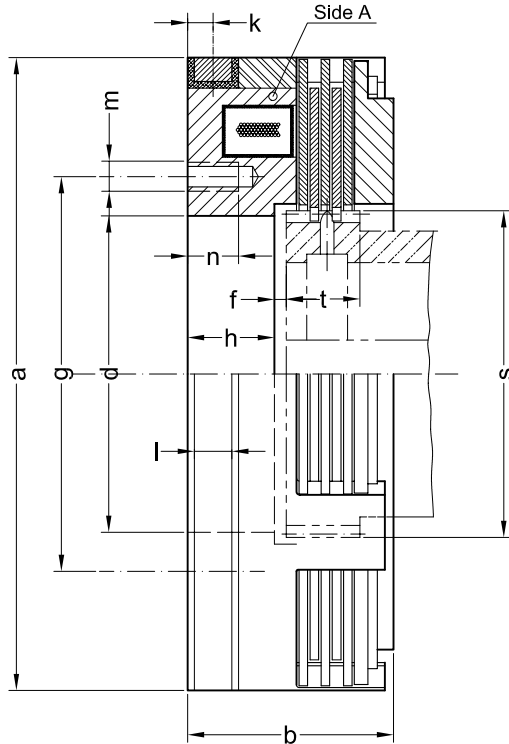

Data and Dimensions		LCW 0,7	LCW 1,5	LCW 3	LCW 6	LCW 12	LCW 20	LCW 30	LCW 50	LCW 80	LCW 125	LCW 200	LCW 300	
Static torque	Nm	12	25	50	100	200	320	500	800	1300	2000	3200	5000	
Dynamic torque	Nm	7	15	30	63	125	200	300	500	780	1250	2000	3000	
Idling torque	Nm	0,06	0,14	0,25	0,5	0,8	1,1	1,8	2,8	3,5	5,5	7,5	10	
Friction work per engagement	kJ	4	6,5	9	15	25	35	50	65	100	160	250	350	
Thermal capacity	W	30	55	80	140	240	350	470	650	900	1300	1700	2200	
Speed maximum	min <sup>-1</sup>	5000	4500	4000	3800	3500	3200	3000	2700	2500	2200	1900	1600	
Torque-Time Constant - to 60 % torque	s	0,12	0,15	0,20	0,25	0,32	0,40	0,50	0,65	0,80	0,95	1,2	1,5	
Disengagement time - to 10 % torque	s	0,04	0,05	0,07	0,10	0,12	0,15	0,20	0,25	0,30	0,35	0,40	0,50	
Coil power consumption at 20 °C	W	12	17	23	27	32	39	43	53	56	75	100	118	
Mass moment of inertia side A	10 <sup>-3</sup> kgm <sup>2</sup>	0,35	0,7	1,6	3,8	8,6	13,4	24	47	75	140	290	510	
Mass (weight)	kg	0,48	0,78	1,2	2,0	3,3	4,3	6,0	8,9	12	18	27	37	
Ø a	mm	70	80	95	112	134	147	165	190	210	240	275	310	
b	mm	23	29,5	35	41	46	50	56	62	68	78	88	96	
Ø d max H7	mm	30	35	48	55	65	72	85	98	105	120	140	160	
f	mm	1,5	1,5	2	2	3	3	3	3	3	3	4	4	
Ø g	mm	36	43	52	65	75	85	90	105	120	140	170	190	
h	mm	12	15	18	21	22	22	24	28	29	34	38	41	
k	mm	5	5	6	6	7	7	7	7	8,5	8,5	8,5	8,5	
l	mm	6	8	8	8	8	8	8	8	10	10	10	10	
m	mm	M4	M5	M6	M6	M8	M8	M8	M10	M12	M12	M16	M16	
n	mm	6	7	8	10	10	12	12	15	18	18	20	20	
t min.	mm	6	10	11	13	15	18	20	20	24	27	30	34	
Inner driver 1)	module 2)	mm	1,5	1,5	1,5	1,5	2	2	2,5	2,5	3	3	3	
	number of teeth	-	22	26	35	40	34	38	35	40	36	41	47	54
	s addendum circle Ø 3)	mm	34	40	53	61	69	77	89	102	110	126	144	164
	root circle Ø	mm	29,25	35,25	48,75	56,25	63	71	81,25	93,75	100,5	115,5	133,5	154,5
	measured over tooth number	-	3	3	4	5	4	5	4	5	4	5	6	6
w - 0,05 tooth width	mm	11,48	11,56	16,18	20,71	21,55	27,57	26,99	34,55	32,44	41,50	50,61	50,90	

1) basic tooth profile as per DIN 867, zero profile offset 2) pressure angle 20° 3) addendum correction