

Electromagnetic Stationary Field Single-Face Clutch

Pole face friction clutch with diaphragm plate to be screwed on the free wheeling gear part.

For dry operation, coil voltage 24 V DC

- ◆ Speed changing clutch for precise operation cycle control.
- ◆ With diaphragm made of hardened spring steel.
- ◆ Self-acting adjustment by magnetic flux permeated friction faces.
- ◆ No idling torque because of complete disconnection of the drive transmission in disengaged position.
- ◆ Vertical mounting, only when ordered with application guidelines.

The diaphragm permits a free of backlash and friction less clutch operation, thereby allowing a constant repeatable time response.

Within the life span of the friction faces the clutch does not require any maintenance. The diaphragm connected with the armature plate has to be screwed to the gear part to be coupled - see example shown in the drawing.

The air gap "i" given in the table must be set during the installation of the clutch to the prescribed value.

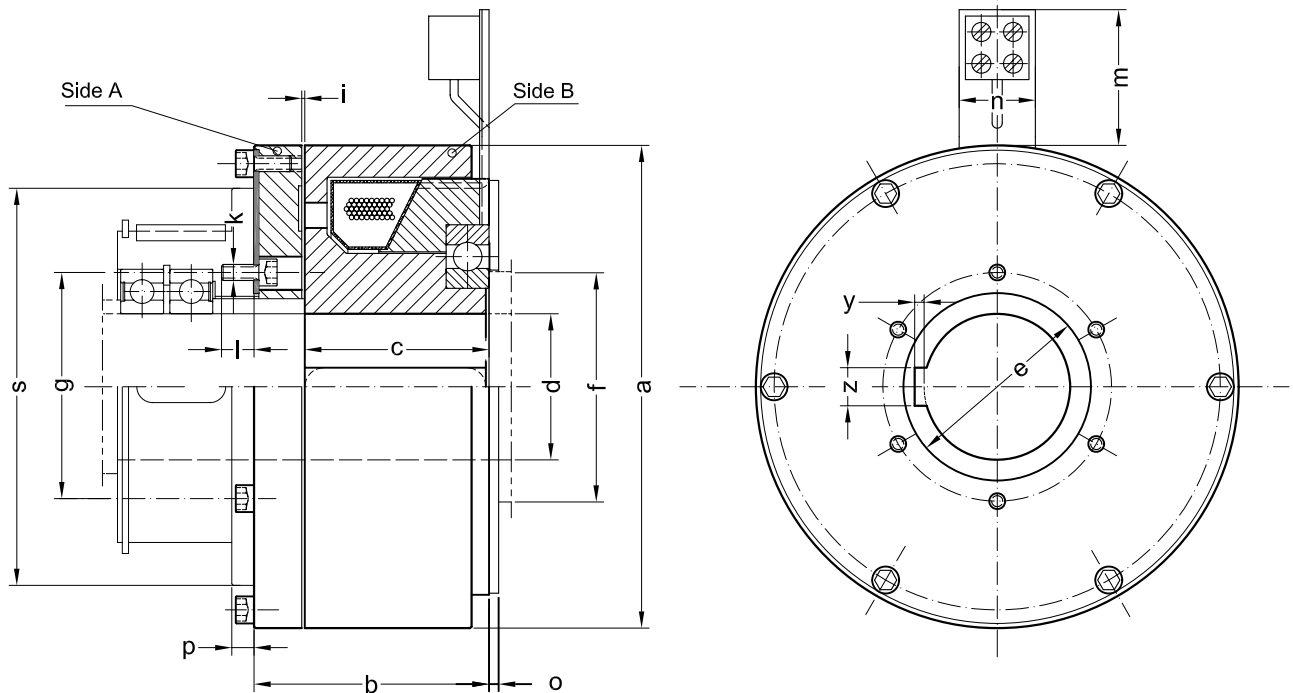

Data and Dimensions			FOSMS 0,4	FOSMS 0,8	FOSMS 1,2	FOSMS 2,5	FOSMS 5	FOSMS 10
Static torque	Dry - / oil operation	Nm	5 / 2	10 / 4	15 / 6	30 / 12	60 / 25	120 / 50
Dynamic torque		Nm	4 / 1,2	8 / 2,4	12 / 3,6	25 / 7,5	50 / 15	100 / 30
Thermal capacity		W	20 / 30	25 / 40	40 / 60	60 / 90	75 / 110	110 / 160
Oil quantity- for maximum heat discharge		l/min	~ 0,2	~ 0,3	~ 0,4	~ 0,5	~ 0,7	~ 0,9
Friction work per engagement		kJ	3,3	3,7	7,5	13,8	20,5	38
Initial delay- for engagement		ms	20	20	30	30	30	40
Torque-time constant ¹⁾		ms	30	40	50	70	100	120
Disengagement time ²⁾		ms	20	20	30	40	50	70
Speed maximum		min ⁻¹	7000	6000	5000	4000	3200	2500
Coil power consumption at 20 °C		W	20	25	30	50	60	80
Mass moment of inertia side A	10 ⁻³ kgm ²		0,09	0,16	0,35	1,1	2,8	9
Mass moment of inertia side B	10 ⁻³ kgm ²		0,17	0,4	1	2,5	8,8	22,5
Mass (weight)		kg	1	1,5	2,5	4	6,5	12,5
∅ a		mm	64	72	86	107	130	164
b		mm	39	42,5	50	57	66	80
c		mm	31	34	40	45	51	61
∅ d H7		mm	10	10	20	30	35	40
∅ e H7		mm	18	20	31	42	56	62
∅ f		mm	27	32	43	52	62	82
∅ g		mm	25	28	40	52	62	76
i		mm	0,2	0,2	0,3	0,3	0,4	0,4
k		mm	6 x M3	6 x M4	6 x M4	6 x M4	6 x M6	6 x M6
l		mm	5	5	7	6	10	10
m		mm	63	62	62	58	100	93
n		mm	22	22	22	22	30	30
o bearing cover		mm	2,5	2,5	2,5	3	3	3
p		mm	4	4	4	5	6	6
∅ s		mm	45	50	65	80	90	110
keyway z x y		mm	4 x 1,1	4 x 1,1	6 x 1,7	8 x 1,7	10 x 2,1	12 x 2,1

1) up to 60% of full torque rate

2) drop to 10% of full torque rate